

# Manual Bike Pump



**Spec Sheet**

**P:** 1300 596 636  
**E:** [Sales@velopushbikeparkingsolutions.com](mailto:Sales@velopushbikeparkingsolutions.com)  
**W:** [velopushbikeparkingsolutions.com](http://velopushbikeparkingsolutions.com)  
**ABN:** 72672981396

# Manual Bike Pump - Specifications



## Description:

Sleek design and durable material are some of the key features of this timeless manual bike pump. With a Schrader and Presta valve, gauge, and effortless handling makes this a reliable tool with no worries.

## Features:

- Hand Pump
- Wheel Catcher
- Schrader & Presta valve
- Pressure gauge
- Robust, smooth handle

## Technical Data:

Body Height: **760mm (1110mm handle at full extension)**  
Body Width: **300mm**  
Body Depth: **240mm**

Weight: **5kg**

Base Plate: **190mm x 140mm**

## Required Space:

Height: **1500mm**  
Width: **2000mm**  
Depth: **400mm**  
Front Clearance: **1500mm**

## Material:

Stainless steel and Aluminum (handle)  
Finishes:  
Mill finish

## Applications:

Bicycle storage rooms, Recreation centres,  
Schools, Universities, Colleges, Shopping centres etc.

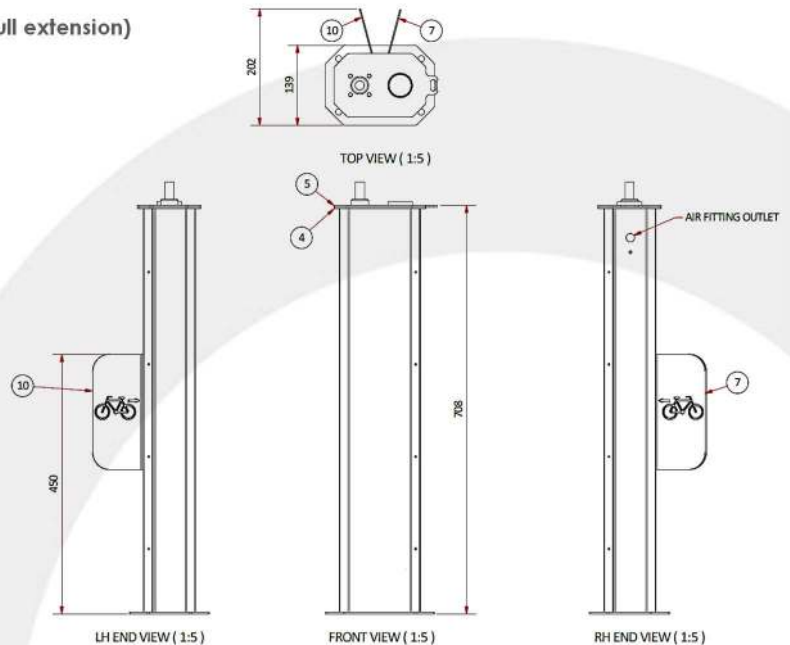

**P: 1300 596 636**  
**E: Sales@velopushbikeparkingsolutions.com**  
**W: velopushbikeparkingsolutions.com**  
**ABN: 72672981396**

# Additional Information

## Fixing/Anchor:

M10x50 Stainless Steel Sleeve Anchor (Dynamabolt)

## Foundation material and requirements:

Concrete: min. thickness 100mm and without signs of damage

## Warranty:

Velo-PBPS gives a 5-year warranty on this product, effective from the handover date.

We warrant that the equipment (and material) complies with the relevant standards at the date of install.

This warranty is limited and may be excluded in part or in full in case of user damage, misuse, or faulty installation.

Frequent visual inspections for signs of damage or need for cleaning are recommended.

Report damaged products.

## Disclaimer:

Images may differ from actual product and specifications may change without prior notice. Velo-PBPS is not liable for the structural integrity of the foundation material and quality and any queries shall be raised with the authorized installer.

## Maintenance:

Used components do not require maintenance.

If any parts appear to be malfunctioning report immediately.

## Cleaning:

Ensure adequate cleaning is carried out during and after installation, such as removal of construction materials like concrete, plaster, and paint splashes.

Immediate removal prevents use of aggressive cleaning in the future, that may harm the products.

Regular cleaning shall be carried out with Stainless Steel suitable and approved solutions.

## WARNING:

Use of unsuitable and aggressive solvents may harm the surface and corrosion protection and therefore the appearance of the product.

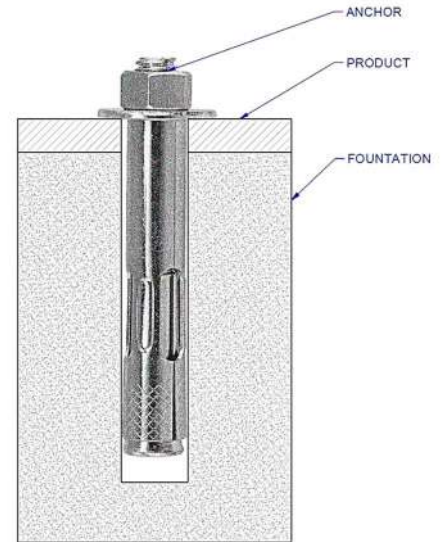

Figure 1: M10x50 DYNABOLT  
(SLEEVE ANCHOR)

Say **velo** for a new Standard  
in Bicycle Parking!



Velo Pushbike Parking Solutions Pty Ltd  
proudly designs, manufactures, and  
operates from Brisbane, Australia.

**P:** 1300 596 636  
**E:** [Sales@velopushbikeparkingsolutions.com](mailto:Sales@velopushbikeparkingsolutions.com)  
**E:** [velopushbikeparkingsolutions.com](http://velopushbikeparkingsolutions.com)  
**ABN:** 72672981396